



UDC: 582.681.81

*Original scientific paper*

## Physical Properties of Wood in White Poplar Clone 'L-12' Grown in Republic of Croatia and Serbia

Tomislav Sedlar <sup>1,\*</sup>, Iva Ištok <sup>1</sup>, Gordana Orešković <sup>1</sup>, Srđan Stojnić <sup>2</sup>, Ernest Goršić <sup>1</sup>, Bogoslav Šefc <sup>1</sup>

<sup>1</sup> University of Zagreb, Faculty of Forestry, Svetošimunska cesta 25, 10000 Zagreb, Croatia

<sup>2</sup> University of Novi Sad, Institute of Lowland Forestry and Environment, Antona Čehova 13, 21000 Novi Sad, Serbia

\* Corresponding author: Tomislav Sedlar; E-mail: tsedlar@sumfak.hr

**Abstract:** Due to increasing demand for forest products, fast-growing species such as poplars are grown in plantations to a larger extent. The quality of wood raw material depends to a greater extent on its physical properties. The available data on physical and mechanical properties of white poplar wood grown in Republic of Croatia and Serbia are insufficient. In this article, preliminary results on physical properties of white poplar clone 'L-12' wood grown in Republic of Croatia and Serbia are presented. Five representative trees of white poplar clone 'L-12' from two sites were collected. One is located near the city of Osijek in the Republic of Croatia, within Osijek Podravina forests and the other one is located at Experimental Estate of the Institute of Lowland Forestry and Environment "Kačka šuma" near the city of Novi Sad in the Republic of Serbia. Both sites are representatives of breeding poplar plantations. The investigations were carried out using only segments with north and south orientation in wood at the breast height of each tree. The results of average values indicate that there is no significant difference in wood density in clone 'L-12' between two sites. There is significant difference in longitudinal, tangential and volume shrinkage and maximal moisture content between sites, but the difference, as far as practice is concerned, is negligible. For a better prediction of wood quality of clone 'L-12' further research on mechanical properties of wood is needed.

**Keywords:** physical properties, sites, white poplar clone 'L-12'.

### 1. Introduction

Increased demand for forest products will cause lack of quality wood on the market in the future. To satisfy demands, fast-growing genetically improved wood species have been introduced. One of them are hybrid poplars. Poplars are one of more easily cloned wood species. Usually their rotations are up to 15 years. There are many researches on hybrid poplars. Mostly, investigations were focused on growth rate, coppicing ability, adaptability and disease resistance while investigations about wood quality of selected poplar clones were investigated to a lesser extent. The wood of poplars is predicted for numerous uses, such as lumber and veneer production, production of composite and wood-based products, pulp and paper etc. Physical

properties are important for better understanding and prediction of wood quality (Zobel and van Buijtenen, 1989), especially wood density and wood shrinkage. Poplar wood density is similar to that of softwoods, but with high strength values related to their limited density (Isebrands and Richardson, 2014). Wood shrinkage is influenced by its density. Greater shrinkage is usually associated with greater density (Tsoumis, 1991). Many studies on wood shrinkage on poplars have been carried out (Pliura et al. 2005; Kord et al. 2010, Ištók et al. 2016; Sinković et al. 2017).

White poplar (*Populus alba* L.) is native wood species in Europe. Considering constant climatic changes, white poplars are resistant to drought (Eggens et al., 1972, Isebrands and Richardson, 2014) and tolerant to changes in groundwater levels (Rédei and Keserü, 2008). In Republic of Croatia, it could be found in mixed stands together with other species such as white willow and black poplar. Pure stands of white poplar could be found along the course of Danube, Sava and Drava (Franjić and Škvorc, 2010). Until now, research has been carried out on anatomical, physical and mechanical properties of white poplar wood (*Populus alba* L.) in Croatia (Horvat, 1960; Ištók et al. 2017; Sinković et al. 2017). The capacity of white poplar to grow in a wide range of soils and to propagate easily contributes highly to its cultivation. White poplar clone 'L-12' has been planted in the Republic of Croatia and Serbia. Data on anatomical, physical and mechanical properties of clone 'L-12' are missing.

The aim of this preliminary study was: (a) to determine wood physical properties of white poplar clone 'L-12' from two sites, one in Croatia and the other one in Serbia; (b) to investigate variations in mentioned properties between two sites.

## 2. Materials and Methods

For the purpose of this research, five representative trees of white poplar clone 'L-12' from two sites were collected. One is located near the city of Osijek in the Republic of Croatia, within Osijek Podravina forests. The site is characterized by alluvial loamy-sandy soils, where humus is being formed, with mean annual temperature of 11.6 °C and total annual precipitation of 694.4 mm. The second site is located at Experimental Estate of the Institute of Lowland Forestry and Environment "Kačka šuma" (N 45°17'; E 19°53'; 76 m a.s.l.) near the city of Novi Sad in the Republic of Serbia. It is characterized by undeveloped alluvial soil (fluvisol), sandy loam form. Mean annual temperature is 11.1°C, while the annual sum of precipitation is 624 mm. During the vegetation period (April-September) mean air temperature is 17.8°C and the sum of precipitations amounts 369 mm.

**Table 1.** Tree characteristics of white poplar clone 'L12' from two sites.

Tree species	Tree mark	Site	Total tree height (m)	Height up to first living branch (m)	Diameter at breast height (cm)	Disk thickness (cm)
'L12'	1K	Osijek	22.3	4	28.7	5
'L12'	2K	Osijek	25	3	35.7	5
'L12'	3K	Osijek	19.5	8	28.4	5
'L12'	4K	Osijek	20	8	28.7	5
'L12'	5K	Osijek	18	12	25	5
'L12'	11	Novi Sad	30	6	36	5
'L12'	12	Novi Sad	35.5	10	37.3	5
'L12'	13	Novi Sad	38	8	35.5	5
'L12'	14	Novi Sad	40	10	40.3	5
'L12'	15	Novi Sad	39	8	36.5	5

Each test tree was marked on the side facing north. They were chosen as representative of the stand according to ISO 3129:2012. Relevant parameters were collected and measured on growth locations of all test trees (Table 1).

After cutting down, one test trunk, length of approximately 80 cm, was sawn from each test tree. Afterwards, trunks were sawn into bark to bark cores of approximately 6 cm in thickness (Figure 1). The samples were sawn in the radial direction from heart to bark and labelled with markers. After the cores had dried to a moisture content of about 12%, from the highest part of the core, which was in at breast height (1.3 m), rectangular samples of 20 mm × 20 mm × 25 mm were made (Figure 1).

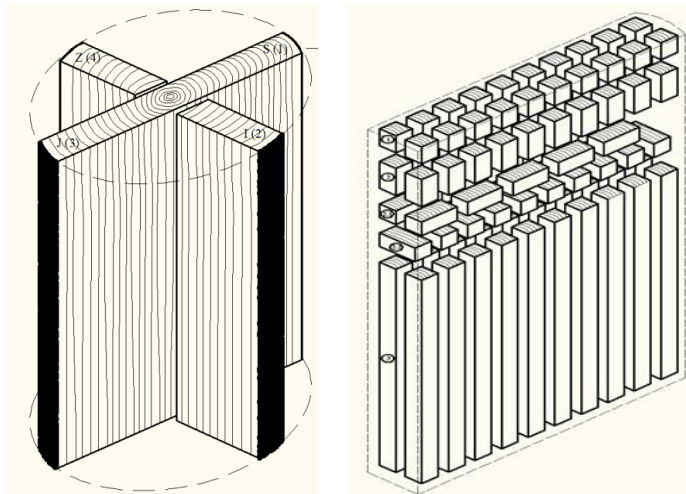

**Figure 1.** Bark to bark core (North – South) and samples of 20 mm × 20 mm × 25 mm from core (1).

Physical properties that were determined in this study were density in absolutely dry condition and basic density according to HRN ISO 13061-2, radial and tangential shrinkage according to HRN ISO 4869:1999 and volumetric shrinkage according to HRN ISO 4858:1999.

Statistical analysis of the results and their comparison was carried out in specialised statistical programme Statistica 8. Statistical analysis showed the number of measured samples (n), minimum (min), average (aver) and maximum (max) value of certain measured properties as well as their standard deviation (STDEV) and coefficient of variation (CVAR).

### 3. Results and Discussion

Physical properties of wood, especially wood density and dimensional stability are important factors affecting wood quality. Average wood density in absolutely dry condition of clone 'L-12' from Novi Sad is only 1% higher than in clone 'L-12' from Osijek (Table 2). Statistical analysis showed no difference in average wood density between sites (Table 3 and Figure 3).

Average basic density values in 'L-12' is 0.28 g/cm<sup>3</sup>. The values from our results are smaller than findings of other authors for hybrid poplars (Beaudoin et al. 1992; Hernández et al. 1998; Zhang et al. 2003). According to them, basic wood density ranges between 0.3 and 0.4 g/cm<sup>3</sup>.

**Table 2.** Statistical values of density in absolutely dry condition, basic density, maximal radial, tangential and volume shrinkage of white poplar clone 'L-12' from Novi Sad and Osijek.

'L-12' - Novi Sad					'L-12' - Osijek					
Q <sub>0</sub>	Q <sub>y</sub>	β <sub>r max</sub>	β <sub>t max</sub>	β <sub>v max</sub>		β <sub>v max</sub>	β <sub>t max</sub>	β <sub>r max</sub>	Q <sub>y</sub>	Q <sub>0</sub>
g/cm <sup>3</sup>	g/cm <sup>3</sup>	%	%	%		%	%	%	g/cm <sup>3</sup>	g/cm <sup>3</sup>
160	160	160	160	160	N	68	68	68	68	68
0.273	0.245	2.8	5.6	9.5	MIN	9.9	6.5	2.9	0.235	0.259
0.318	0.283	4.0	8.1	12.6	AVE	11.9	7.6	3.8	0.281	0.314
0.433	0.382	8.6	9.9	17.9	MAX	15.9	9.5	8.4	0.352	0.396
0.0258	0.0221	0.98	0.85	1.48	STDEV	1.12	0.64	0.79	0.0298	0.0347
8.10	7.81	24.24	10.53	11.72	CVAR	9.42	8.50	20.68	10.62	11.03

**Legend:** Q<sub>0</sub> - density in absolutely dry condition, Q<sub>y</sub> - basic density, β<sub>r max</sub> - total radial shrinkage, β<sub>t max</sub> - total tangential shrinkage and β<sub>v max</sub> - total volumetric shrinkage, N - number of specimens, MIN - minimal value, MAX - maximal value, STDEV - standard deviation, CVAR - coefficient of variation (%).

There is statistical difference in tangential and volumetric shrinkage of clones between two sites (Table 3 and Figure 2). However, the difference in shrinkage is only about 6%, and for wood processing and forestry practice could be negligible. The average values of shrinkages in clone 'L-12' wood are similar to some native poplars (Peck, 1957; Jessome, 1977) and poplar clones (Koubaa et al. 1998).

**Table 3.** Pearson’s correlation coefficients for the relationship between mean values of researched physical properties of poplar clone 'L-12' from Novi Sad and Osijek.

'L-12' - Novi Sad \ 'L-12' - Osijek	Density in the absolutely dry condition	Basic density	Total radial shrinkage	Total tangential shrinkage	Total volumetric shrinkage
Density in the absolutely dry condition	p=0.179 Z=1.343				
Basic density		p=0.388 Z=0.862			
Total radial shrinkage			p=0.307 Z=1.020		
Total tangential shrinkage				p<0.001 Z=5.080	
Total volumetric shrinkage					p<0.001 Z=3.961

Note: Correlations are significant at p<0.05.

The effect of environmental conditions on 'L-12' clone wood physical properties was evaluated across two sites situated in Croatia and Serbia. Negligible clone differences observed between sites concerning wood shrinkage, as well as absence of differences in average wood density suggest relatively stable performance of 'L-12' in two environments. Such a performance is probably the result of similar environmental conditions in Kačka šuma and Osijek Podravina forests, since previous studies demonstrated that majority of variation depends on the

environment. Indeed, Yan and Kang (2002) believe that environmental effect contributes more than 80 % of totally observed variation.

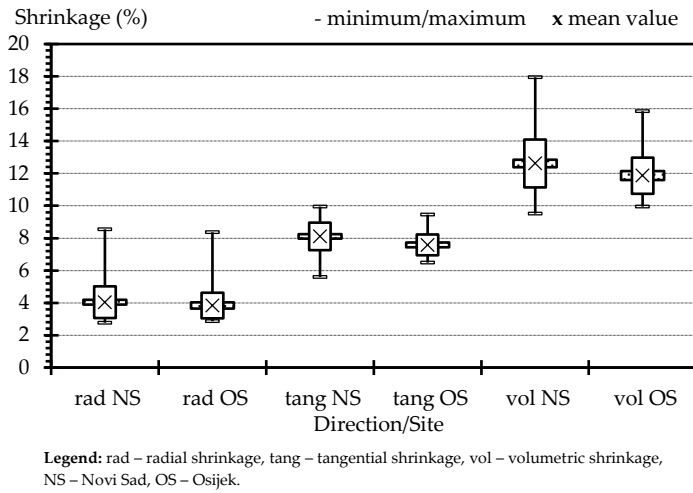

**Figure 2.** Statistical analyzes of radial, tangential and volumetric shrinkage between clone 'L-12' from two sites.

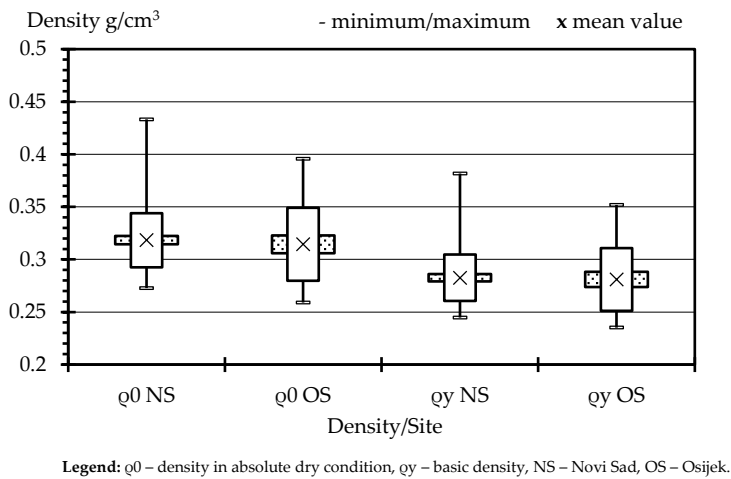

**Figure 3.** Statistical analyzes of density between clone 'L-12' from two sites.

#### 4. Conclusions

Clone performances generally remain constant from one environment to another. Although significant differences in tangential and volumetric shrinkage of white poplar clone 'L-12' were observed between two sites, these differences amounted only about 6%, which is for the purpose of wood processing and forestry practice negligible. Likewise, no difference was found in wood density between sites.

Similar performances of white poplar clone 'L-12' across two sites probably rely on the low environmental variation (i.e. soil conditions and microclimate) between sites where the plantations have been cultivated. Nevertheless, the stability observed for wood shrinkage and density might be the results of certain morphological and physiological aspects which hold these traits in a fixed state, while allowing other characters to vary (Allard and Bradshaw, 1964).

Therefore, for better understanding of wood structure in white poplar clone 'L-12', as well as the effect of local environment on them, mechanical properties should be investigated in the future.

### Acknowledgements

*The examined issues constitute a part of the project: "Kratkoročna financijska potpora istraživanju 2015; Anatomska, fizikalna, mehanička i kemijska svojstva drva bijele topole (Populus alba L.) i klonova bijele topole uz rijeku Dravu". This work was financed by University of Zagreb, Croatia.*

### 5. References

- Allard, R.W., Bradshaw, A.D. (1964): Implications of genotype-environmental interactions in applied plant breeding. *Crop Science* 4: 503-508.
- Beaudoin, M., Hernandez, R.E., Koubaa, A., Poliquin, J. (1992): Interclonal, intracolon and within-tree variation in wood density of poplar hybrid clones. *Wood and Fiber Science* 24(2):147-153.
- Eggens, C.F., Longheed, E.C., Hilton, R.J. (1972): Rooting of hardwood cuttings of boleana poplar. *Can J Plant Sci* 52: 599-604. *Cited in Kovačević, B. et al., SEEFOR ISSN 1847-6481, 3-12.*
- Franjić, J., Škvorc, Ž. (2010): Šumsko drveće i grmlje Hrvatske. Sveučilišni udžbenik, Šumarski fakultet Sveučilišta u Zagrebu: 264.
- Hernández, R.E., Koubaa, A., Beaudoin, M., Fortin, Y. (1998): Selected mechanical properties of fast-growing poplar hybrid clones. *Wood and Fiber Science* 30(2):138-147.
- Horvat, I. (1960): Prilog poznavanju nekih fizičkih i mehaničkih svojstava bijele i crne topolovine (*Populus alba* L., *Populus nigra* L.). *Šumarski list* 3-4, 95-115.
- Isebrands, J.G., Richardson, J. (2014): *Poplars and willows: trees for society and the environment*, FAO.
- Ištok, I., Sedlar, T., Šefc, B., Sinković, T., Perković, T. (2016): Physical Properties of Wood in Poplar Clones 'I-214' and 'S1-8'. *Drvna industrija* 67(2), 163-170.
- Ištok, I., Šefc, B., Hasan, M., Popović, G., Sedlar, T. (2017): fiber characteristics of white poplar (*Populus alba* L.). juvenile wood along the Drava River. *Drvna industrija* 68 (3): 241-247.
- Jessome, A.P. (1977): Strength and related properties of the wood grown in Canada. Rpt. 21. Eastern Forest Product Lab, Ottawa. *Forestry Tech.*: 37 pp.
- Kord, B., Kialashaki, A., Kord, B. (2010): The within-tree variation in wood density and shrinkage, and their relationship in *Populus euramericana*. *Turkish Journal of Agriculture and Forestry* 34(2010) 121-126. Doi: 10.3906/tar-0903-14.
- Koubaa, A., Hernandez, R.E., Beaudoin, M. (1998): Shrinkage of fast-growing hybrid poplar clones. *Forest Products Journal* 48, 82-87.
- Peck, E.C. (1957): How wood shrinks and swells. *Forest product Journal* 7(7): 235-244.
- Pliura, A., Yu, Q., Zhang, S.Y., Mackay, J., Pierre, P., Bousquet, J. (2005): Variation in wood density and shrinkage and their relationship to growth young poplar hybrids crosses. *Forest Science Journal* 51: 472- 482.

15. Rédei, K., Keserü, Zs. (2008): Promising white poplar (*Populus alba* L.) clones in sandy ridges between the rivers Danube and Tisza in Hungary. *International Journal of Horticultural Science* 14(1-2): 113-116.
16. Sinković, T., Jambreković, B., Šefc, B., Ištok, I., Veselčić, F., Sedlar, T. (2017): Some Physical and Mechanical Properties of White Poplar (*Populus alba* L.) Wood Grown in Varaždin Region, 28<sup>th</sup> International of Wood Science in Woodworking Sector, Zagreb, ISBN: 978-953-292-053-6: 101-107.
17. Tsoumis, G. (1991): Science and technology of wood: structure, properties, utilization. Chapman & Hall, New York.
18. Yan, W., Kang, M.S. (2002): GGE biplot analysis. A graphical tool for breeders, geneticists, and agronomists. Florida, United States: CRC press: 288pp. ISBN 0849313384
19. Zhang, S.Y., Yu, Q., Chauret, G., Koubaa, A. (2003): Selection for Both Growth and Wood Properties in Hybrid Poplar Clones. *Forest Science* 49(6): 901-908.
20. Zobel, B.J.; Van Buijtenen, J.P. (1989): Wood Variation, Its Causes and Control. Springer-Verlag, Berlin, Heidelberg, Germany.
21. \*\*\* HRN ISO 3129:2012: Drvo – Metode uzorkovanja i opći zahtjevi za ispitivanje fizikalnih i mehaničkih svojstava na manjim uzorcima masivnog drva
22. \*\*\* HRN ISO 13061-2: Fizikalna i mehanička svojstva drva – Metode ispitivanja za manje uzorke masivnog drva – 2. Dio: Određivanje gustoće za provođenje ispitivanja fizikalnih i mehaničkih svojstava
23. \*\*\* HRN ISO 4858:1999: Drvo – Određivanje volumnog utezanja.
24. \*\*\* HRN ISO 4469:1999: Drvo – Određivanje radijalnog i tangencijalnog utezanja.

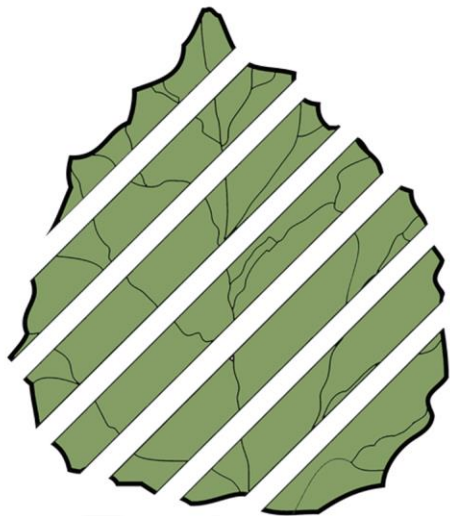

# Topola Poplar

SINCE 1957

2019 (MMXIX)  
Vol. 203 (Special Issue)

Novi Sad  
Serbia

ISSN: 0563-9034  
E-ISSN: 2620-1593



[www.ilfe.org](http://www.ilfe.org)



Cover photo by Dr. Leopold Poljaković-Pajnik

*Vegetative seed orchard of Pedunculate oak (Quercus robur L.) colonized by Oak lace bug (Corythucha arcuata (Say, 1832))*



---

2019 (MMXIX)

NOVI SAD

Vol. 203

---

*Special issue from the conference session:  
"How to Advance Forestry for Future Generations"  
organized within  
The 15<sup>th</sup> International Phytotechnology Conference*

*The Conference session was dedicated to the 60th Anniversary of the foundation of the  
Institute of Lowland Forestry and Environment*

**ISSN (print): 0563-9034**

**ISSN (online): 2620-1593**

**Publisher**

University of Novi Sad – Institute of Lowland Forestry and Environment

Antona Čehova 13d, 21000 Novi Sad, Serbia

Tel: +381 21 540 383, +381 21 540 384

Fax: +381 21 540 385

URL: [www.ilfe.org](http://www.ilfe.org)

E-mail: [journal.poplar@uns.ac.rs](mailto:journal.poplar@uns.ac.rs)

**Editor-in-Chief**

Prof. Dr. Saša Orlović

**Executive Editor**

Dr. Branislav Kovačević

**Copy Editor**

Dr. Leopold Poljaković-Pajnik

**UDC Classification**

Matica Srpska, Novi Sad, Serbia

**Press**

"DIV print"

Žarka Zrenjanina 21a

21205 Sremski Karlovci

Serbia

**Circulation:**

75

## Editorial Board

Dr. David Tsao, International Phytotechnology Society, President, USA  
Dr. Jason C. White, International Phytotechnology Society, Immediate Past president, USA  
Dr. Barbara Zeeb, International Phytotechnology Society, Executive Vice President, Canada  
Dr. Om Parkash Dhankher, International Phytotechnology Society, Vice President, USA  
Dr. Liz Rylott, International Phytotechnology Society, Vice President, UK  
Dr. Elena Maestri, International Phytotechnology Society, Secretary, Italy  
Dr. Ronald S. Zalesny Jr, USDA Forest Service, Institute for Applied Ecosystem Studies, USA  
Prof. Dr. Luca Sebastiani, University of Santa Anna, Italy  
Prof. Dr. Michael Marek, Czech Globe, Czech Republic  
Prof. Dr. Libor Jankovsky, Mendel University, Brno, Czech Republic  
Prof. Dr. Hojka Kraigher, Slovenian Forestry Institute, Slovenia  
Dr. Filippos Aravanopoulos, Aristotle University of Thessaloniki, Greece  
Dr. Evangelia V. Avramidou, Institute of Mediterranean Forest Ecosystems, Athens, Greece  
Acad. Prof. Dr. Alexander Alexandrov, Bulgarian Academy of Sciences, Bulgaria  
Dr. Miglena Zhiyanski, Bulgarian Academy of Sciences, Forest Research Institute, Bulgaria  
Dr. Thomas Cech, Federal Research and Training Centre for Forests, Austria  
Acad. Prof. Dr. Karoly Redei, Forest Research Institute Center, Hungary  
Dr. Attila Borovics, Forest Research Institute Center, Hungary  
Dr. Jozef Turok, Technical University in Zvolen, Faculty of Forestry, Slovakia  
Dr. Lubica Ditmarová, Institute of Forest Ecology SAS, Zvolen, Slovakia  
Dr. Eva Pšidova, Institute of Forest Ecology SAS, Zvolen, Slovakia  
Dr. Roman Longauer, NFC – Forest Research Institute, Slovakia  
Dr. Sanja Perić, Croatian Forest Research Institute, Croatia  
Dr. Dinka Matošević, Croatian Forest Research Institute, Croatia  
Dr. Bogoslav Šefc, University of Zagreb, Faculty of Forestry, Croatia  
Dr. Iva Ištok, University of Zagreb, Faculty of Forestry, Croatia  
Dr. Tomislav Sedlar, University of Zagreb, Faculty of Forestry, Croatia  
Dr. Jelena Lazarević, University of Montenegro, Biotechnical Faculty, Montenegro  
Dr. Magdalena Kacprzyk, University of Agriculture, Krakow, Poland  
Prof. Dr. Florian Borlea, Banat University of Agricultural Science and Veterinary Medicine, Romania  
Prof. Dr. Milan Mataruga, University of Banja Luka, Faculty of Forestry, Republic of Srpska (BA)  
Prof. Dr. Ratko Ristić, University of Belgrade - Faculty of Forestry, Serbia  
Dr. Ljubinko Rakonjac, Institute of Forestry, Serbia  
Prof. Dr. Vasilije Isajev, University of Belgrade, Faculty of Forestry, Serbia  
Dr. Danijela Miljković, Institute for Biological Research "Siniša Stanković", Belgrade, Serbia  
Dr. Milena Stefanović, Institute for Biological Research "Siniša Stanković", Belgrade, Serbia  
Dr. Leopold Poljaković-Pajnik, Institute of Lowland Forestry and Environment, Serbia  
Dr. Milica Zlatković, Institute of Lowland Forestry and Environment, Serbia  
Dr. Srđan Stojnić, Institute of Lowland Forestry and Environment, Serbia  
Dr. Zoran Galić, Institute of Lowland Forestry and Environment, Serbia  
Dr. Andrej Pilipović, Institute of Lowland Forestry and Environment, Serbia  
Dr. Dejan B. Stojanović, Institute of Lowland Forestry and Environment, Serbia  
Dr. Vladislava Galović, Institute of Lowland Forestry and Environment, Serbia  
Dr. Branislav Kovačević, Institute of Lowland Forestry and Environment, Serbia  
Dr. Siniša Andrašev, Institute of Lowland Forestry and Environment, Serbia  
Dr. Saša Pekeč, Institute of Lowland Forestry and Environment, Serbia  
Dr. Verica Vasić, Institute of Lowland Forestry and Environment, Serbia  
Dr. Predrag Pap, Institute of Lowland Forestry and Environment, Serbia  
Dr. Miroslav Marković, Institute of Lowland Forestry and Environment, Serbia  
Dr. Milan Drekić, Institute of Lowland Forestry and Environment, Serbia  
Dr. Bratislav Matović, Institute of Lowland Forestry and Environment, Serbia  
Dr. Marina Katanić, Institute of Lowland Forestry and Environment, Serbia  
Dr. Mirjana Stevanov, Institute of Lowland Forestry and Environment, Serbia  
Dr. Marko Kebert, Institute of Lowland Forestry and Environment, Serbia  
Dr. Dejan V. Stojanović, Institute of Lowland Forestry and Environment, Serbia

## Content

- 5-11 Michael M. Okeyo, Gilbert O. Obwoyere, Dickson L. Makanji, Jane W. Njuguna, Jackline A. Omondi  
**FUNGAL DISEASES ATTACKING FLORAL PHENOLOGY OF *Terminalia Brownii* IN DRYLANDS, KENYA**
- 13-18 Vanja Vuksanović, Branislav Kovačević, Saša Orlović, Marko Kebert, Milica Kovač  
**THE INFLUENCE OF DROUGHT ON GROWTH AND DEVELOPMENT OF WHITE POPLAR SHOOTS IN VITRO**
- 19-30 Branislava Batos, Milorad Veselinović, Ljubinko Rakonjac, Danijela Miljković  
**MORPHOLOGICAL PROPERTIES OF POLLEN AS BIOINDICATORS OF DECIDUOUS WOODY SPECIES IN BELGRADE PARKS (SERBIA)**
- 31-35 Evangelia V. Avramidou  
**EPIGENETICS VS GENETICS: UNRAVELING THE IMPORTANCE BEYOND THE GENE IN NATURAL FOREST POPULATIONS**
- 37-43 Iva Ištok, Bogoslav Šefc, Tomislav Sedlar, Ernest Goršić, Mijo Mihić, Srđan Stojnić  
**FIBER LENGTH IN CLONE 'L-12' JUVENILE WOOD**
- 45-51 Tomislav Sedlar, Iva Ištok, Gordana Orešković, Srđan Stojnić, Ernest Goršić, Bogoslav Šefc  
**PHYSICAL PROPERTIES OF WOOD IN WHITE POPLAR CLONE 'L-12' GROWN IN REPUBLIC OF CROATIA AND SERBIA**
- 53-63 Martina Zorić, Igor Đukić, Ljubomir Kljajić, Dragić Karaklić, Saša Orlović  
**THE POSSIBILITIES FOR IMPROVEMENT OF ECOSYSTEM SERVICES IN TARA NATIONAL PARK**
- 65-69 Plamen Mirchev, Margarita Georgieva, Gergana Zaemdzhikova, Maria Matova, Sianna Hlebarska, Eva Filipova, Georgi Georgiev  
**PHENOLOGICAL FORM DIVERSITY OF *Thaumetopoea pityocampa* IN BULGARIA**
- 71-78 Georgi Georgiev, Mara Tabaković-Tošić, Margarita Georgieva, Plamen Mirchev  
***Lymantria dispar* MORTALITY IN PUPAL STAGE CAUSED BY *Entomophaga maimaiga* IN BULGARIA AND SERBIA**
- 79-85 Alexander H. Alexandrov, Ivan Iliev  
**FORESTS IN SOUTH-EASTERN EUROPE**
- 87-94 Leopold Poljaković-Pajnik, Milan Drekić, Branislav Kovačević, Milena Stanković-Nedić, Srđan Stojnić, Saša Orlović  
**HOST PREFERENCE OF *Myzus cerasi* (FABRICIUS, 1775) TO HALF-SIB LINES OF *Prunus avium* L. FROM SIX POPULATIONS ASSESSED IN THE NURSERY TRIAL**

## About Journal

POPLAR is a semestrial open access scientific journal that publishes peer-reviewed original research articles, review articles, preliminary reports and professional papers, on topics dealing with forestry, horticulture, and environmental sciences. The papers are published in English and Serbian.

POPLAR was founded in 1957 by the Institute of Lowland Forestry and Environment (formerly known as Poplar Research Institute), in Novi Sad, Serbia.

While "poplar" in the journal title reflects single tree species that is of great importance for the lowland forestry, the journal is open for research papers dealing with all tree species, as well as other annual and perennial plant species occurring in the forest ecosystems.

The journal is published both online and in printed versions.

This special issue is dedicated to the 60th Anniversary of the foundation of the Institute of Lowland Forestry and Environment. The special issue includes papers submitted to and presented at the scientific conference "How to Advance Forestry for Future Generations", organized on 2<sup>nd</sup> and 3<sup>rd</sup> October 2018, in Novi Sad, Serbia.